

Simple step-by-step installation



SIEMENS

Safety precautions

2

Warning:
Read the safety precautions and the user guide on the CD before use. Explain their content and the potential hazards associated with using the telephone to your children.

- > Only use the mains adapters supplied, as indicated on the underside of the base station or charging cradle.
- > Only use the **recommended, rechargeable batteries**, i.e. never use a conventional (non-rechargeable) battery or other battery types as this could result in significant health risks and personal injury. For example, the outer casing of the batteries could be damaged or the batteries could explode. The phone could also malfunction or be damaged as a result of using batteries that are not of the recommended type.
- > Insert rechargeable batteries with the correct polarity, and use them in accordance with the user guide (polarity symbols are displayed in or on the handset's battery compartment).
- > Batteries should not be disposed of in general household waste. Observe the local waste disposal regulations, details of which can be obtained from your local authority or the dealer you purchased the product from.
- > The operation of medical appliances may be affected. Be aware of the technical conditions in your particular environment, e.g. doctor's surgery.
- > Do not hold the rear of the handset to your ear when it is ringing or when the handsfree function is activated. Otherwise you risk serious and permanent damage to your hearing. The handset may cause an unpleasant humming noise in hearing aids.
- > Do not install the base station or charging cradle in bathrooms or shower rooms. The handset, base station and charging cradle are not splashproof.
- > The charging cradle and base station are designed for use in enclosed dry rooms with a temperature range of +5°C to +45°C.
- > Do not use the phone in environments with a potential explosion hazard, e.g. paint shops.
- > Never expose the telephone to any of the following: heat sources, direct sunlight or other electrical appliances.
- > Protect your Gigaset from moisture, dust, corrosive liquids and vapours.
- > If you give your Gigaset to someone else, make sure you also give them the user guide.
- > Please remove faulty base stations from use or have them repaired by our Service Centre, as they could interfere with other wireless services.
- > All electrical and electronic equipment must be disposed of separately from general household waste using the sites designated by local authorities.



If a product displays this symbol of a crossed-out rubbish bin, the product is subject to European Directive 2002/96/EC. The appropriate disposal and separate collection of used equipment serve to prevent potential harm to the environment and to health. They are a precondition for the re-use and recycling of used electrical and electronic equipment. For further information on disposing of your used equipment, please contact your local authority, your refuse collection service or the dealer you purchased the product from.

Warning:
When the keypad lock is active, you cannot call emergency numbers.

Pack contents

3



- Gigaset A580 IP base station
- Mains adapter for connecting the base station to the mains power supply
- Phone cord for connecting the base station to the fixed line network
- Ethernet (LAN) cable for connecting the base station to the router (LAN/Internet)
- Gigaset A58H handset
- Two batteries for the handset (uncharged)
- Battery compartment cover for the handset
- Handset charging cradle
- Mains adapter for connecting the charging cradle to the mains power supply
- CD with the user guide for your Gigaset.
If the firmware for your base station is updated, the user guide will also be updated and made available for download on the Internet at www.gigaset.com.

Keys and functions on the handset

4



- Display keys**
Start function displayed to the left or right of the bottom display line
- Press up: handsfree key**
Switch between earpiece and handsfree mode (key lights up)
- Press down: talk key**
After entering number: start dialling via VoIP/fixed line network (press briefly/press and hold); accept call
- Control key:**
Press up: Set call volume, ringer and advisory tones
Press down: Open directory
Press up/down: Navigate menus and text
Press up: message key
Open calls and messages lists;
Flashes: new message/new call or
New base station firmware/new provider profile available
Press down: end call, on/off key
End call, cancel function (press briefly)
Return to idle status (press and hold)
Switch handset on/off (press and hold)
- Fast access key** (press and hold):
Messages on the network mailbox
- * key:** Ringer on/off (press and hold)
- # key:** Keypad lock on/off (press and hold)
- Recall/pause key** (fixed line network)
- Open **internal list**



A31008-M2013-L101-2-7643

Connection overview

5

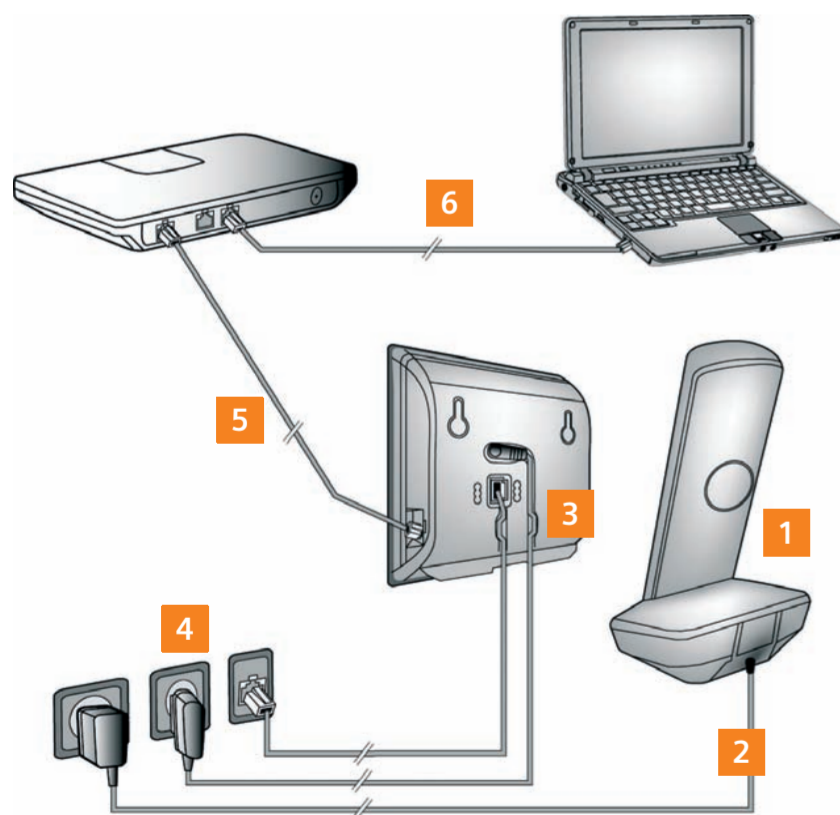

- Preparing the handset: inserting the batteries
- Connecting the charging cradle to the mains power supply and charging the batteries
- Connecting the phone cord and power lead to the base station
- Connecting the base station to the fixed line network and the mains power supply
- To connect the base station to the Internet, first connect the base station to the router (connection via router and modem or via router with integrated modem)
- PC in LAN (optional) – for advanced configuration of the Gigaset A580 IP base station

Preparing the handset

6

- Inserting the supplied batteries and closing the battery cover



- > Check the polarity when inserting the batteries (see symbols in or on the battery compartment).
- > Only use the recommended rechargeable batteries.

Once the batteries have been inserted, the handset switches on automatically.

- Insert the battery compartment cover into the notches at the top of the battery compartment.
- Then press the battery compartment cover until it clicks into place.

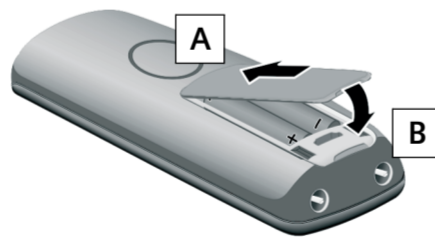

> The display is protected by a plastic film. Please remove the protective film!

- Connecting the charging cradle and charging the batteries

- Observe the sequence (A, B)!



> Place the handset in the charging cradle and wait until the batteries are fully charged.

- > Do not put the handset back in the charging cradle until the batteries are fully discharged through use.
- > After the first battery charge and discharge, you may place your handset in the charging cradle after every call.
- > The battery charging status is displayed in the idle display: (flat to full).

Connecting the base station

7

- Connecting the phone cord and power lead to the base station

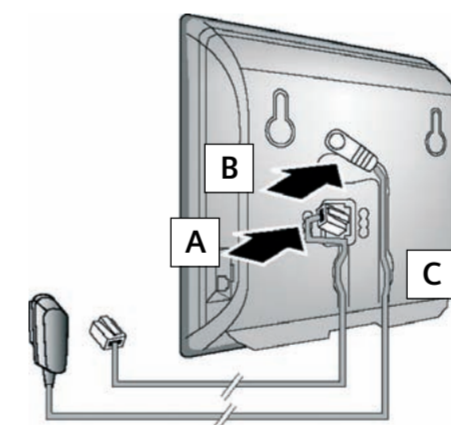

- Insert the phone cord into the lower connection socket at the rear of the base station.
- Insert the power lead of the mains adapter into the upper connection socket at the rear of the base station.
- Insert both cables into their respective cable recesses.

Only use the supplied phone cord and the supplied mains adapter.

- Connecting the base station to the fixed line network and mains power supply

- Insert the phone cord into the fixed line network connection socket.
- Then insert the mains adapter into the mains socket.

Keep the mains adapter **plugged in at all times** for operation, as the phone does not work without a mains connection.

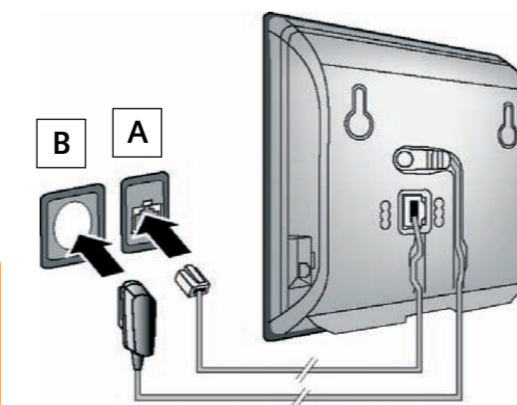

You can now use your phone to make calls via the fixed line network: Enter the number using the handset, and then press and **hold** the talk key .

Connecting the base station

8

- Connecting the base station with the router (Internet)

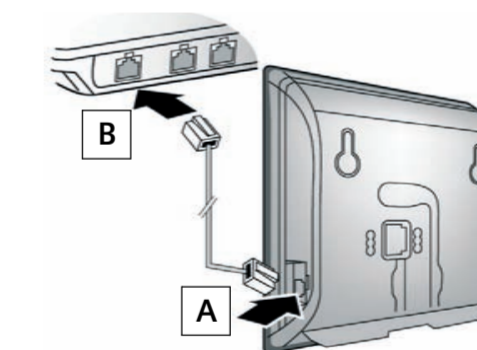

- Connect one Ethernet cable plug to the LAN socket at the side of the base station.
- Insert the second Ethernet cable plug into a LAN socket on the router.

Use the Ethernet cable supplied.

As soon as the cable connecting the phone and router is plugged in and the router is switched on, the key lights up on the front of the base station (paging key).

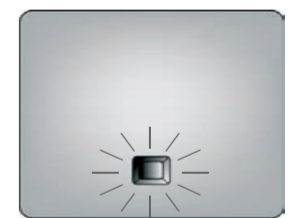

- Connecting the PC to the router (optional)

You can change the settings on the phone's base station using a PC connected to your phone via the router.

- > Connect the PC network connection to a free LAN socket on your router.

> The procedure below requires that your phone is automatically assigned an IP address by the router (i.e. DHCP is enabled on router and phone). In **exceptional cases** (e.g. if DHCP is not enabled on the router) you will have to assign a static IP address to the base station for LAN access. You must enter this IP address on the handset before carrying out the following steps. Further information can be found in the user guide on the enclosed CD.

The following handset menu can be used to make the entry:
Menu → **Settings** → **Base** → **Local Network** → (enter system PIN)

- > IP should be set as the default line for your phone (default setting). You will then immediately receive corresponding messages if a connection to the provider's VoIP server cannot be established due to incorrect/incomplete data.

Instead of using the following procedure, you can also enter the VoIP access data using your PC (steps 7 to 11):

- > Launch the Web browser on your PC.
- > Enter the URL <http://www.gigaset-config.com> in the address field of the Web browser and press the return key.

You are connected to your base station's Web configurator. You can find a description of the Web configurator in the user guide on the enclosed CD.

Precondition for the following steps:

Before you can use VoIP to phone any other subscribers on the Internet, the fixed line network or the mobile phone network, you need a VoIP account.

- > Set up a VoIP account with a VoIP provider.
- > Have the VoIP account data you received from your VoIP provider to hand.

You will need:

- > Your registration name (login ID), your password and, if applicable (provider-dependent), a user name (often this is your VoIP phone number).

Or

- > Your personal auto-configuration code (activation code), if your provider supports "automatic configuration".

7 Starting the configuration process



When your handset is sufficiently charged (approx. 20 minutes after you have placed it in the charging cradle), the message key on the handset flashes.

- > Press the message key on the handset.

If "Update firmware?" is shown in the display, an updated firmware is already available on the Internet for your phone. Press the right-hand display key . The new firmware is loaded. The process takes approx. 3 minutes. The message key will now flash again.

- > Press the message key to start configuration.

8 Starting the connection assistant, entering the PIN



- > Press the key below **Yes** on the display (= right display key).



- > Using the number keys, enter the base station's system PIN. By default, the PIN is "0000".

- > Press the right-hand display key .

If the connection assistant does not start properly, you can start it via the menu:

Menu → **Settings** → **Base** → **Telephony** → **Connection Assistant**

Provided that your phone is set for auto-configuration (default setting), you will see the following display. Otherwise go to 10.

If you have received an **auto-configuration code**:

- > Press the right-hand display key **Yes**.
- > For more information, see 9.

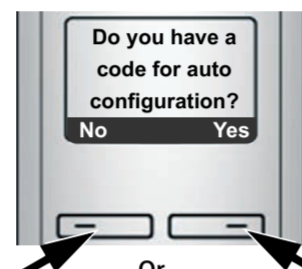

If you have received a **registration name/password** and, if applicable, a user name:

- > Press the left-hand display key **No**.
- > For more information, see 10.

9 Entering an auto-configuration code

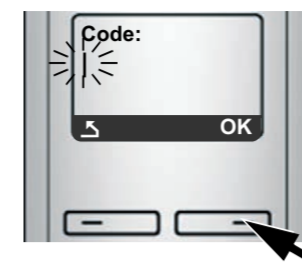

- > Enter your auto-configuration code using the keypad (max. 32 characters).
- > Press the right-hand display key .

All data necessary for VoIP telephony is loaded directly from the Internet to your phone. Following successful download, Saved is shown in the display.

Proceed as described under 12.

10 Selecting a provider and loading provider data to the base station

Select country is displayed briefly in the display. A list of countries is loaded and the first country in the list is shown in the display.

Select provider is displayed briefly in the display. A list of providers is loaded and the first provider is shown in the display.

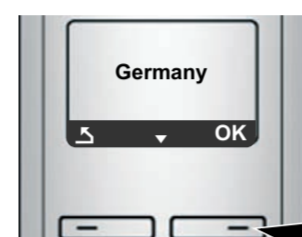

- > Press the bottom of the control key repeatedly, until your country is displayed.
- > Press the display key .

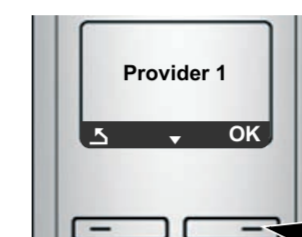

- > Press the bottom of the control key repeatedly, until your provider is displayed.
- > Press the display key .

If your provider does not appear in the list, you have the following options:

- > Press the left display key twice and continue as described in 11. However, you can only make a call via VoIP once you have completed the provider details using the Web configurator. Your VoIP provider will supply you with this data.
- > Exit the connection assistant by holding the end call key and entering the provider and VoIP account details via the Web configurator.

You will find more detailed information about this in the user guide on the enclosed CD.

11 Entering VoIP account data

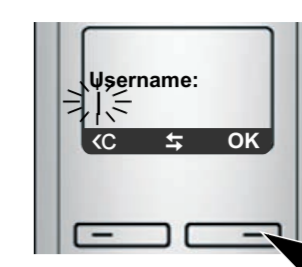

If your VoIP provider does not require a username, this step can be skipped.

- > Using the number keys, enter your username (user ID) that you received from your VoIP provider. This entry is case-sensitive.
- > Press the right-hand display key .

- > To switch between upper and lower case and digits, press the key (several times if necessary).

- > Characters entered incorrectly can be deleted using the left display key . The character to the left of the cursor will be deleted.
- > You can navigate within the input field using the control key (press up/down).

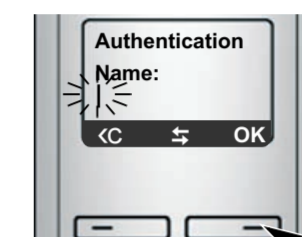

- > Using the number keys, enter your authentication name (user ID). This entry is case-sensitive.

- > Press the right-hand display key .



- > Using the number keys, enter your authentication password. This entry is case-sensitive.

- > Press the right-hand display key .

If you have made all the required entries, Saved will appear on the display.

You can enter five additional VoIP accounts (VoIP phone numbers) via your base station's Web configurator. You will find more information in the user guide on the enclosed CD.

12 Completing and testing VoIP settings

The handset switches to idle status. The idle display status is displayed.

If all the settings are correct and if the phone can establish a connection to the VoIP server, the internal name of the handset will be displayed: (example)



You can now use your phone to make calls via the fixed line network and the Internet! Callers can contact you on your fixed line network number, your Gigaset.net number or your VoIP number!

To ensure that you can always be reached via the Internet, the router must be permanently connected to the Internet.

Testing your VoIP connection

If a message is displayed when you are trying to make a call via VoIP, you can check the base station's connection to the Internet by e.g. calling the Gigaset.net echo service:

- > Enter one of the following phone numbers:

12341#9 (English)	12342#9 (Dutch)	12343#9 (Italian)
12344#9 (French)	12345#9 (German)	12346#9 (Spanish)

- > Press the talk key .

- > When prompted, speak into the microphone on the handset.

If you hear your own voice, your base station is connected to the Internet.

If you do not hear your voice, check your phone and router settings.

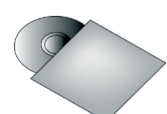

In the user guide on the enclosed CD, you will find detailed information about setting up and operating your phone, as well as possible solutions to frequently asked questions and common problems.

Entering your name in the Gigaset.net directory

Gigaset.net™ is a VoIP service provided by Gigaset Communications GmbH, which you can use to make **free calls** to other Gigaset VoIP users.

The first time you open the Gigaset.net directory, complete the following steps and an entry will be created in the Gigaset.net directory for you.

- > Press down on the control key to open the handset directory.
- > Press down on the control key repeatedly until Gigaset.net is selected.
- > Press the green talk key .

A connection to the Gigaset.net online directory is established. You will see the following display:



- > Press the right-hand display key **Yes**.



- > Using the number keys, enter the name that you would like to be listed under in the Gigaset.net directory.

- > Press the right-hand display key .

If an entry already exists with this name, the message "Please choose another name." will appear. You will be prompted to enter a name again.

If an entry in the Gigaset.net directory is successful, the message "Name added to Gigaset.net" will be shown.

Making calls

- > Enter a phone number using your handset's number keys.

Please note that, even with local calls, you must always dial the area code for calls via VoIP (provider-dependent).

- > **Briefly** press the talk key if you want to make a call via **VoIP**.

Or

- > Press and **hold** the talk key if you want to make a call via the **fixed line network**.

An icon in the top right of the display tells you what line you are using for the call:

- is displayed if you are making a call via VoIP.
- is displayed if you are making a call via the fixed line network.

We offer you support that is fast and tailored to your specific needs!

Our Online Support on the Internet can be reached any time from anywhere.

www.gigaset.com/customer-care

It provides you with 24/7 support for all our products. It also provides a list of FAQs and answers plus user guides and current software updates (if available for the product) for you to download.

You will also find frequently asked questions and answers in the detailed user guide on the enclosed CD or in the Internet at www.gigaset.com.

For personal advice on our range of products and assistance with repairs or guarantee/warranty claims you can contact us on:

UK helpdesk: 0 84 53 67 08 12.

Please have your proof of purchase ready when calling with regard to guarantee/warranty claims.

Replacement or repair services are not offered in countries where our product is not sold by authorised dealers.

Please address any questions about DSL access and VoIP access to the respective service provider.

Authorisation

This device is intended for analogue phone lines in the UK.

Voice over IP telephony is possible via the LAN interface if an additional modem has been connected.

Country-specific requirements have been taken into consideration.

We, Gigaset Communications GmbH, declare that this device meets the essential requirements and other relevant regulations laid down in Directive 1999/5/EC.

A copy of the 1999/5/EC Declaration of Conformity is available at this Internet address: www.gigaset.com/docs.

CE 0682

Issued by
Gigaset Communications GmbH, Schlavenhorst 66, D-46395 Bocholt
Gigaset Communications GmbH is a trademark licensee of Siemens AG
© Gigaset Communications GmbH 2009
All rights reserved. Subject to availability. Rights of modifications reserved.

www.gigaset.com

*. Exclusion of liability

Gigaset.net is a voluntary service provided by Gigaset Communications GmbH with no liability or guarantee for the availability of the network. This service can be terminated at any time with a notice period of three months.